Version
02.01August
2006

Digital HF/VHF/UHF Monitoring Direction Finder R&S® DDF 0xE

0.3 MHz to 3000 MHz

- ◆ Outstanding accuracy and sensitivity
- ◆ Compact design
- ◆ Excellent large-signal immunity
- ◆ High adjacent-channel suppression
- ◆ HF range: 1 MHz FFT realtime bandwidth, VHF/UHF range: 2 MHz FFT realtime bandwidth (option: approx. 10 MHz)
- ◆ High DF scan speed of up to 2 GHz/s (option: 10 GHz/s)
- ◆ Wide range of antennas for stationary and mobile applications
- ◆ Direction finding of GSM signals (option)
- ◆ Easy connection to systems via Ethernet and CORBA

*Now approx. 10 MHz realtime bandwidth for VHF/UHF (option)
Significant increase in scan speed
Reduced minimum signal duration*



ROHDE & SCHWARZ

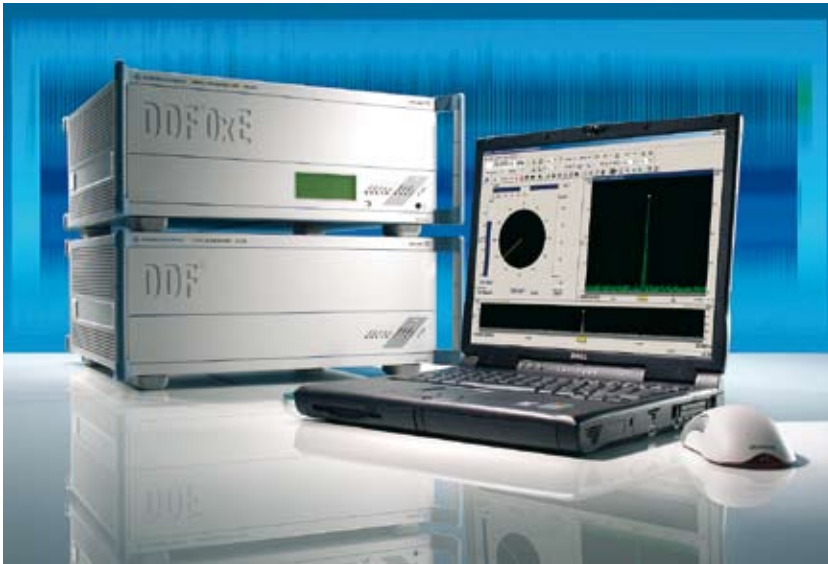

Correlative interferometer

The correlative interferometer has the following advantages over classic methods:

- ◆ Reduction of DF errors caused by reflections and depolarization
- ◆ Determination of a reliable DF quality criterion for evaluating and filtering bearings
- ◆ Possibility of using wide-aperture DF antennas with a minimum number of antenna elements (preferably a circular array)

Moreover, digital signal processing in conjunction with FFT makes it possible to rapidly scan large frequency ranges for activities. The R&S® DDF0xE family of direction finders offers an FFT realtime bandwidth of 1 MHz in the HF range and 2 MHz in the VHF/UHF range (optional: approx. 10 MHz).

General

The Digital HF/VHF/UHF Monitoring Direction Finders R&S® DDF0xE cover the entire frequency range from 0.3 MHz to 3000 MHz or subranges thereof (see table below). The direction finders use digital signal processing both in filtering (FFT and filters with linear phase response) and in bearing calculation.

Each direction finder consists of four functional units:

- ◆ DF antenna system
- ◆ DF converter with integrated receiver modules
- ◆ Digital signal processing unit
- ◆ Control PC and software

The HF DF Converter R&S® EH110 is designed for the frequency range 0.3 MHz to 30 MHz; the VHF/UHF DF Converter R&S® ET550 covers the range 20 MHz to 3000 MHz. The Digital Processing Unit R&S® EBD061 has two IF inputs so that both DF converters (R&S® EH110 and R&S® ET550) can be connected to the R&S® EBD061 (see block diagram on page 3) at the same time. The software of the digital signal processing unit contains as standard the algorithms for DF

evaluation according to the Watson-Watt method and the correlative interferometer.

Digital DF methods

The acronym DDF in the type designation R&S® DDF0xE stands for digital direction finder, indicating that bearings are determined digitally, i.e. the complex antenna voltages are measured by a high-quality three-path DF receiver that acts like a vector voltmeter and are subsequently digitized. The bearings are evaluated using mathematical algorithms. Both the classic Watson-Watt direction finding method and the modern correlative interferometer method can be used.

The Watson-Watt method is preferably used in the HF range in cases where only limited space is available for setting up a DF antenna (e.g. on ships). Moreover, it enables maximum scanning speed.

Type	Application	Frequency range
R&S® DDF01E	HF	0.3 MHz to 30 MHz
R&S® DDF05E	VHF/UHF	20 MHz to 3000 MHz
R&S® DDF06E	HF/VHF/UHF	0.3 MHz to 3000 MHz

Operating and display concept

The DF converter and the digital processing unit do not have control and display elements as standard. The direction finder is operated from a powerful external PC (with Windows XP) that is connected to the R&S®EBD061 via Fast Ethernet. Each direction finder comes with a software package that contains the graphical user interface (GUI) and optional software modules such as the single station locator (SSL) for the short-wave range or GSM direction finding.

Four DF modes are available:

Fixed frequency mode (FFM)

In this mode, the direction finder is operated at a fixed frequency. The bearing is displayed in analog (polar) and digital format. Alternatively, the bearing can be displayed in histogram/waterfall format. For each bearing, the receive level and a quality value (0 to 100) are displayed. In addition to the bearing, the realtime spectrum is displayed, centered to the receive frequency that has been set. The bandwidths for the DF process and the audio demodulation can be set independently of each other.

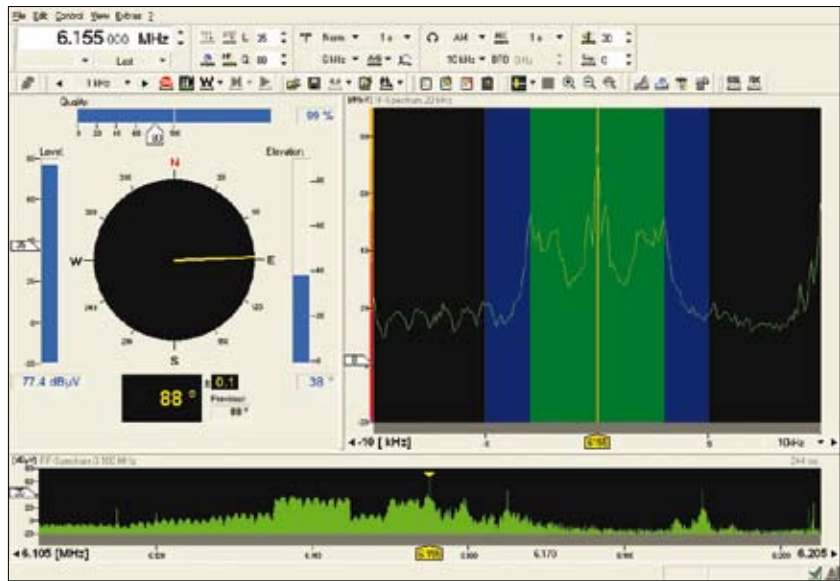

Fixed frequency mode (FFM), search mode

Search mode

In this mode, either a frequency range (defined by start/stop frequency and step width) or a frequency list (with up to 1000 entries) is searched for activities. If the direction finder detects a signal that exceeds a predefined threshold, it dwells on this signal for a selectable length of time. Bearings are presented in the same way as in the fixed frequency mode.

DF scan speed and channel selectivity

When specifying the DF scan speed, it is essential to indicate the selectivity conditions under which the speed is attained. As a basic rule, the lower the channel selectivity, the higher the speed. With lower selectivity, however, adjacent channel suppression may be insufficient, and adjacent occupied channels may mutually influence the respective bearings that are taken. Selectivity is characterized by the shape factor, which indicates the ratio of the bandwidth at 60 dB suppression to the bandwidth at 3 dB suppression of the unwanted adjacent channel. The R&S®DDF0xE has a shape factor of 3.6 in the scan mode. A quantity connected with the shape factor is the product of the measurement time T and the bandwidth B ($B \times T$ or BT). The R&S®DDF0xE has a $B \times T$ of 4 to achieve the desired selectivity characteristics.

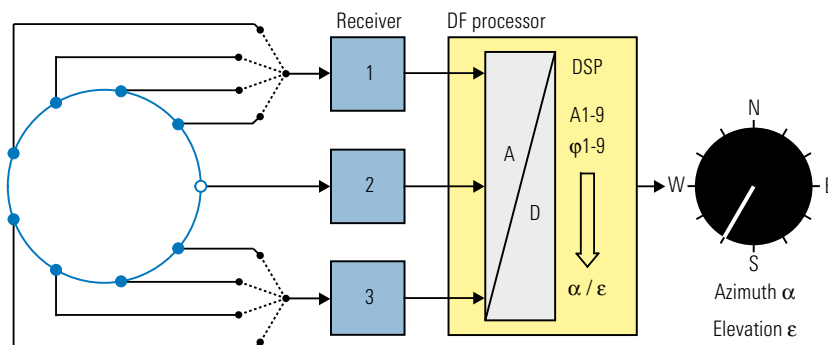

Block diagram of the R&S®DDF0xE

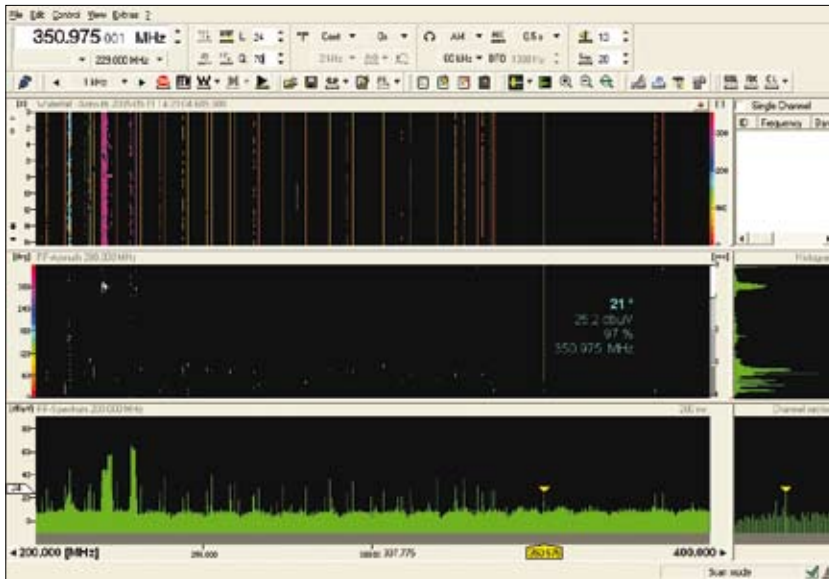

Scan mode

Scan mode (fast DF scanning)

The R&S® DDF0xE family of direction finders also offers the capability to scan defined frequency ranges at a selectable step width (frequency scan) or up to 1000 stored frequency channels (memory scan) for activities. DF results can be displayed in several ways: Basically, all information is shown in a spectral display, i.e. versus frequency. Bearings are

displayed in the azimuth versus frequency mode and can be color-coded according to age, level or azimuth. To reduce data, it is also possible to define azimuth sectors or level and elevation ranges. Specific frequencies can be labeled with scales or markers. Simply by clicking the mouse, the user can then switch to the FFM menu for closer analysis of the selected signal.

**New:
wideband mode**

Wideband mode (WFFM)

In this mode, the direction finder simultaneously takes bearings of all channels that fall within the FFT realtime bandwidth. All relevant parameters such as channel spacing, integration time and DF quality threshold can be directly set.

Results can be displayed in several formats, e.g. spectrum display, bearing versus frequency and waterfall format.

DF scan speed and channel occupancy

The R&S® DDF0xE is one of the very few direction finders available that offers DF scan speed independent of channel occupancy. In other words, the DF scan speed of the direction finder does not vary and is maintained even with 100% channel occupancy. With most conventional direction finders, the DF scan speed decreases rapidly as the channel occupancy increases. For this reason, DF scan speed is usually specified for only 10% channel occupancy. This value is quickly exceeded, however, when bearings of weak signals close to the noise floor are taken or of direct sequence spread spectrum (DSSS) signals within the noise floor.

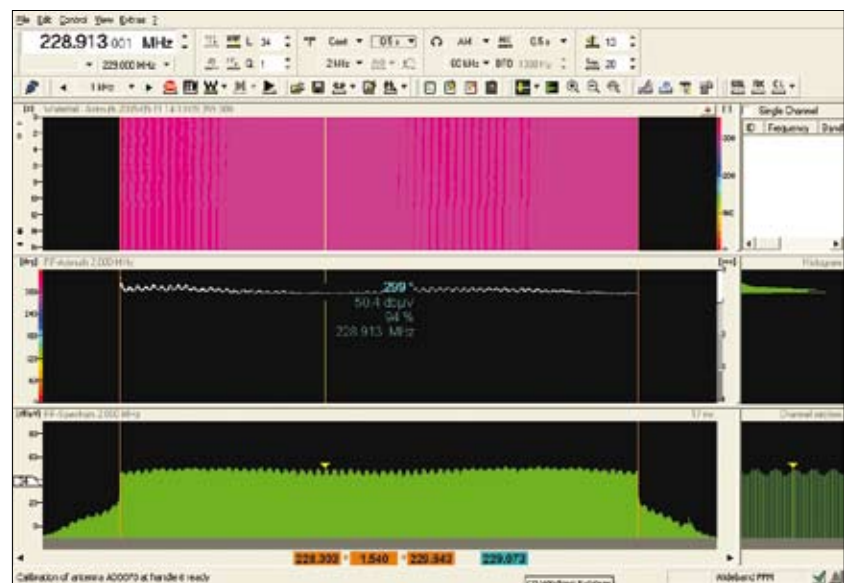

Wideband mode (WFFM)

**New:
parallel averaging of all channels**

The WFFM mode in addition offers the innovative feature of parallel averaging of all channels, which significantly enhances the probability of obtaining bearings of weak signals. Even DSSS signals within the noise floor are reliably detected and their bearings taken.

DF scan speed and channel resolution

The DF scan speed mainly depends on the selected channel resolution. The lower the resolution, the shorter the filter settling time and the higher the DF scan speed. It is therefore important to specify the DF scan speed together with the channel resolution.

DF accuracy and sensitivity

When the R&S®DDF0xE is tested in a real environment, it is impressive for the stable and accurate bearings it delivers even for weak signals. This fact is due to the direction finder's elaborate design concept, which is described in the following.

Based on the concept of virtual receivers

The direction finder was planned from the start with high accuracy and sensitivity in mind. Consequently, the decision was made in favor of the concept of virtual receivers, which offers significant advantages with respect to the aforementioned prerequisites.

The concept of virtual receivers is characterized by a large number of antenna elements being successively connected to a small number of receivers at very high speed, creating the impression that each antenna element is assigned a receive path of its own. The decisive advantage is that large DF antennas with many antenna elements can be used without requiring a corresponding number of receive paths, which would be very costly, because the larger the size of a DF antenna, the more antenna elements are required.

Number of antenna elements

In principle, DF antennas with a larger number of antenna elements can be designed for larger diameters. But using a larger number of antenna elements offers clear advantages even for DF antennas that have identical diameters. For example, a nine-element DF antenna provides higher accuracy and error tolerance than a five-element antenna due to the fact that it delivers nearly twice as many antenna signals to be averaged.

**Larger DF antenna
=
enhanced accuracy and sensitivity**

It is generally known that a direction finder's accuracy and sensitivity in a real environment increase with the diameter of the DF antenna. As already mentioned, this advantage comes into its own only in a real operational environment, which involves reflections and weak signals. It is not obvious from specifications, since in data sheets the instrument and system accuracy are specified for ideal, non-reflecting DF antenna environments and strong signals to provide comparability.

The figure on the left shows that the R&S®DDF0xE, featuring a nine-element array and employing the correlative interferometer DF method, offers by far the largest DF antenna and thus higher accuracy and sensitivity.

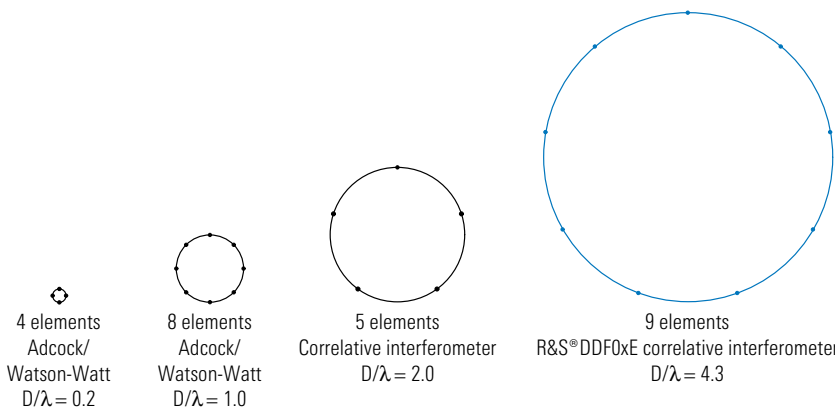

Maximum permissible diameter of the DF antenna relative to the wavelength for unambiguous DF results for up to 50% of environmental reflections

Immunity to reflections

Reflections may basically impair DF accuracy. Depending on their concept, some DF antennas can handle reflections better than others. The R&S®DDF0xE was designed to provide accurate bearings even with a 50% share of reflections of the incoming signal. This high immunity to reflections is due to the large number of antenna elements used.

The figure below shows the improvement in DF accuracy as a function of the DF antenna aperture.

The enhanced accuracy and sensitivity of the R&S®DDF0xE makes it especially suitable for taking bearings

- ◆ of weak signals
- ◆ of spread spectrum or DSSS signals within the noise floor
- ◆ with high accuracy even in non-ideal antenna environments
- ◆ in extremely adverse environments, e.g. urban areas

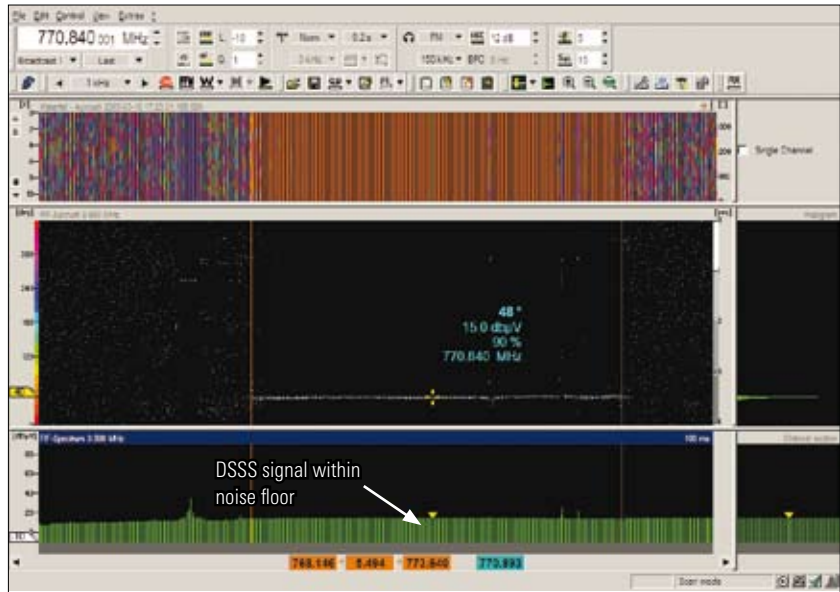

DSSS signal within noise floor (-6 dB)

Innovation: averaging in scan mode

By using averaging during broadband direction finding, a function currently unrivaled, the R&S®DDF0xE reliably detects and takes bearings of signals such as DSSS even if they occur within the noise floor. The R&S®DDF0xE is thus well prepared for this type of data transmission, which is becoming more and more common.

The figure above shows a bearing being taken of a DSSS signal within the noise floor (-6 dB), the signal having a width of approx. 5.5 MHz and a nominal bearing value of 48°. The DSSS signal is not recognizable in the spectrum as the signal-to-noise ratio is negative. The very narrow bearing histogram indicates very low bearing fluctuation and thus a reliable bearing value.

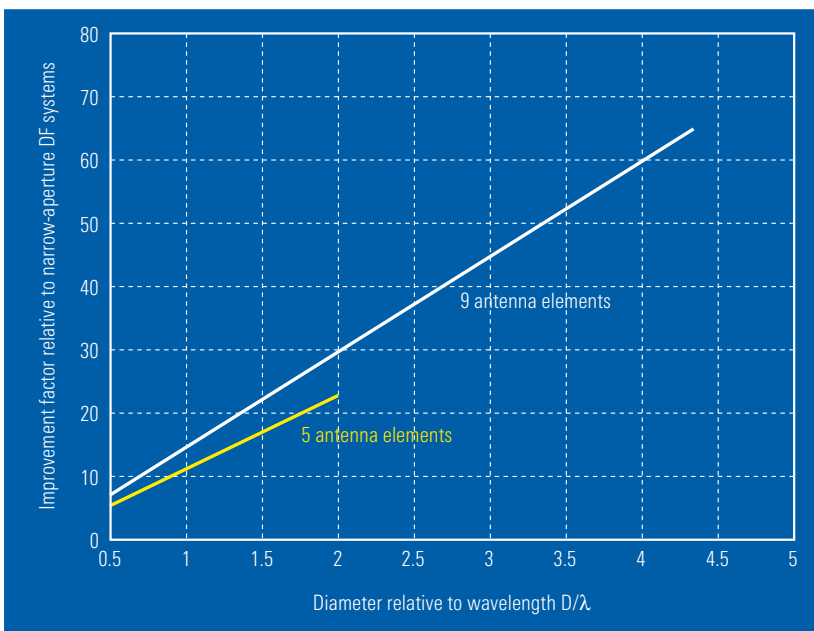

Improvement factor as a function of the DF antenna aperture for the correlative interferometer

High sensitivity for maximum coverage

The R&S®DDF0xE is also remarkable for its sensitivity: From HF to 1.3 GHz, a low field strength of typically 0.2 $\mu\text{V}/\text{m}$ (HF) to 1 $\mu\text{V}/\text{m}$ (VHF/UHF) will suffice to obtain a stable bearing. Above 1.3 GHz, no more than 3 $\mu\text{V}/\text{m}$ to 10 $\mu\text{V}/\text{m}$ is needed.

This makes the R&S®DDF0xE one of the most sensitive direction finders available on the market, which is also due to its high number of antenna elements.

DF sensitivity

At present, there exists no uniform method of measuring and specifying DF sensitivity. It is therefore of vital importance that precise information be given about the measurement method employed. Specifying DF sensitivity without giving any information about the measurement method by which the specified sensitivity was obtained is meaningless, as different methods will produce significantly different results. For Rohde & Schwarz products, DF sensitivity is defined as the minimum field strength required by the direction finder together with the DF antenna in order to yield accurate bearings (see diagrams on page 18, "Sensitivity of DF antennas").

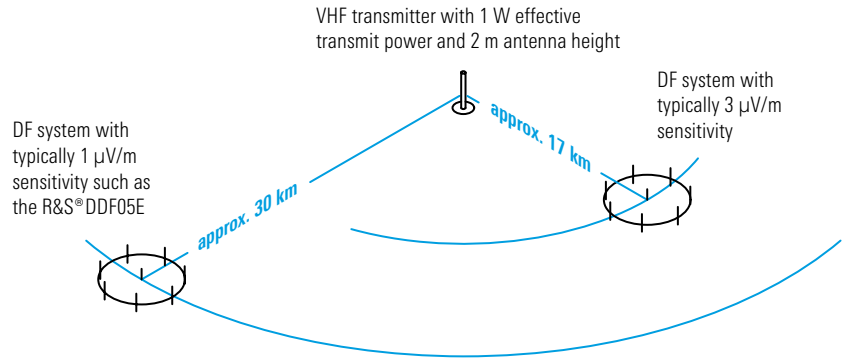

Range comparison of DF systems of different sensitivity for a VHF transmission

The higher the sensitivity, the wider the range of a direction finder. This is shown by the figure above, which compares two DF systems of different sensitivity. The comparison is based on the equations for radio propagation in the VHF range recommended by ITU. According to these equations, the R&S®DDF05E reliably determines the bearing of a 1 W VHF transmitter with a line of sight up to a distance of typically 30 km. For a DF system of lower sensitivity, the distance has to be reduced, and just a few $\mu\text{V}/\text{m}$ already mean a significant reduction in DF range.

High coverage reduces costs

The high sensitivity of the R&S®DDF0xE provides significantly wider coverage. This means that fewer direction finders are needed for monitoring a specific area than would be in the case of less sensitive DF systems, although sensitivity may differ by just a few $\mu\text{V}/\text{m}$.

This substantially reduces costs, as can be seen from the figure below.

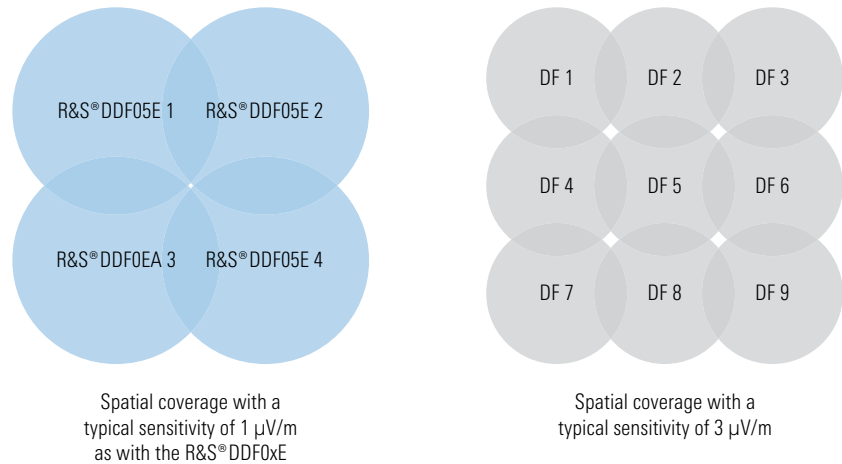

Coverage comparison of DF systems of different sensitivity

Receiver quality

Whether weak signals can be received at all or whether a direction finder can deliver meaningful results, even when located at an unfavorable site in the vicinity of a strong transmitter, largely depends on the quality of the receivers used.

Enhanced immunity to strong signals because of maximum linearity and minimum phase noise

Linearity, which is defined by the second- and third-order intercept (SOI and TOI) points, describes to what extent intermodulation products in the vicinity of strong transmitters become visible. Unfortunately, standardized procedures for measuring SOI and TOI are not yet available. This makes it difficult to compare the quality of different receivers on the basis of data sheet specifications. Where comparable measurements are available, the R&S®DDF0xE receivers frequently have significantly higher and thus better values.

The very low phase noise additionally increases immunity to strong signals.

And here another advantage of the virtual receiver concept comes into play: the fact that only a small number of receive paths is required. The DF converter of the R&S®DDF0xE contains three coherent receive paths. Compared with five-path direction finders, this concept alone reduces costs by 40%. This in turn makes it possible to use receivers of superior quality.

The vital prerequisite: state-of-the-art receivers

Each R&S®DDF0xE version is equipped with three receivers that are among the best available on the world market and have been developed and produced by Rohde & Schwarz itself:

- ◆ The converter for the HF range contains three receivers nearly identical in design with the R&S®EM010
- ◆ The converter for the VHF/UHF range contains three receivers nearly identical in design with the R&S®EM050

Finding a suitable location for a DF antenna is often difficult, in particular in the VHF/UHF range, because strong transmitters, e.g. FM or TV broadcast transmitters, may be located nearby. The R&S®DDF0xE's high linearity and very low phase noise make it possible to install the direction finder closer to strong transmitters.

High linearity makes finding a suitable DF location easier

Simulations show that, with intermodulation products of equal strength, the R&S®DDF0xE can be located approx. 30% closer to a strong transmitter than a direction finder whose intercept points are approx. 10 dB lower. Compared with a direction finder with 18 dB lower intercept points, the R&S®DDF0xE can be installed at even half the distance. This facilitates finding a suitable DF antenna site.

Typical applications of the R&S®DDF0xE direction finder

Stationary VHF/UHF radiomonitoring

For stationary and semimobile VHF/UHF DF systems, the DF antenna system consisting of the R&S®ADD053 and R&S®ADD070 was designed. This antenna system together with the R&S®DDF05E yields an extremely accurate and sensitive DF system.

The entire frequency range is covered by three DF antennas with large diameters, each antenna using eight or nine antenna elements, which is the basis for the DF system's high immunity to reflections and outstanding sensitivity.

At most frequencies, a field strength as low as 1 µV/m suffices to provide accurate bearings (see data sheet on DF Antennas R&S®ADDx).

The DF Antenna R&S®ADD153 is mounted at the top. This antenna covers the frequency range 200 MHz to 1300 MHz. While the R&S®ADD153 can be used down to 20 MHz, the R&S®ADD050 is employed in this range as it offers better results due to its considerably larger size.



R&S®ADD053 and R&S®ADD070 DF antenna system

Maximum accuracy and sensitivity in the VHF range

The center R&S®ADD050 with a diameter of 3 m has been optimized for direction finding in the range 20 MHz to 200 MHz. Together with the R&S®ADD153 and a glass-fiber intermediate mast, it forms the R&S®ADD053 antenna system.

The DF Antenna R&S®ADD070 has been designed for the frequency range 1300 MHz to 3000 MHz. It is available as a very sturdy model capable of supporting the R&S®ADD053 antenna system.

Especially when high masts are used or the control PC is spaced some distance away from the DF equipment, it is advisable to accommodate the DF equipment in the All-Weather Cabinet R&S®KK500. This does away with the need for long coaxial cables, which reduce sensitivity at high frequencies and are very costly.

If the Ethernet link is also implemented by means of a glass-fiber cable, the control PC can be installed several hundred meters away from the DF equipment without any impairment to the DF process.

Product	Brief description
R&S®DDF05E	Fast VHF/UHF monitoring direction finder with high accuracy and sensitivity
R&S®ADD053	DF antenna system for the frequency range 20 MHz to 1300 MHz consisting of the R&S®ADD050 and the R&S®ADD153
R&S®ADD070	DF antenna for the frequency range 1300 MHz to 3000 MHz, sturdy version (02), permitting the R&S®ADD053 to be mounted on top of it
R&S®KK500	All-weather cabinet for the DF equipment

Mobile GSM direction finding

With the GSM option installed, the R&S® DDF05E is capable of taking the bearing of every mobile phone active in a channel. Depending on the number of occupied timeslots, up to eight bearings will be displayed on the GUI. Taking bearings of mobile phones places exacting demands on a direction finder, given that a single GSM signal packet has a duration of only 577 μ s. The R&S® DDF05E, which requires a minimum signal duration of only 400 μ s, also provides reliable bearings for GSM mobile phones.

Moreover, Rohde & Schwarz offers the DF Antenna R&S® ADD170, which has been specially developed for mobile phone direction finding and offers the following outstanding characteristics:

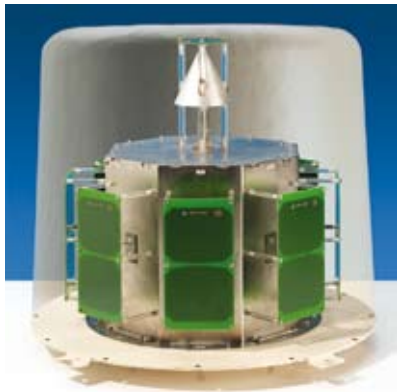

DF Antenna R&S® ADD170

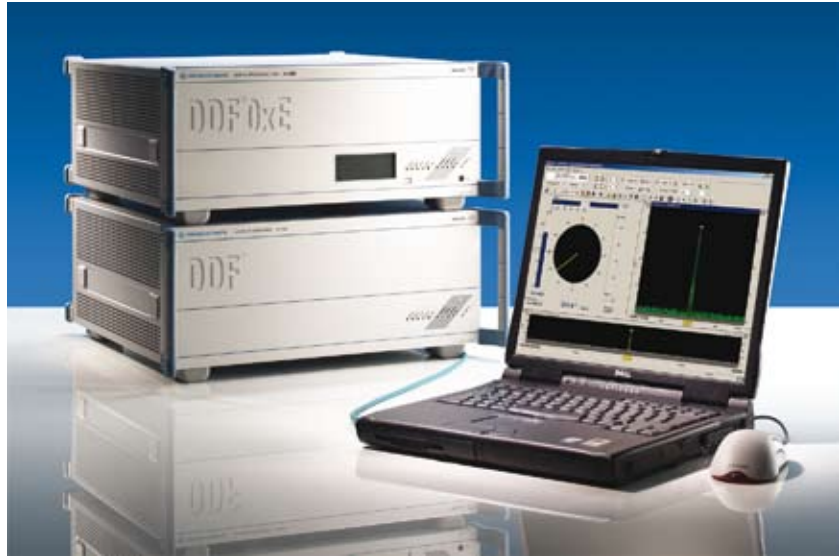

R&S® DDF05E

- ◆ Excellent DF accuracy due to large antenna diameter
- ◆ Enhanced immunity to reflections due to optimized antenna geometry
- ◆ Maximum sensitivity due to focusing on GSM frequency range of 800 MHz to 2000 MHz
- ◆ Compact design for camouflaged installation in a plastic caddy on a vehicle roof

Taking bearings of mobile phones in urban areas is always a challenge, considering the large amount of shadowing and reflections that must be handled. The R&S® DDF05E in conjunction with the R&S® ADD170 delivers extraordinarily accurate and stable bearings even under these very difficult conditions.



Product	Brief description
R&S® DDF05E	Very fast VHF/UHF monitoring direction finder with high accuracy and sensitivity
R&S® ADD170	Compact DF antenna optimized for the GSM band
R&S® DDF-GSM	DF option for taking bearings of all occupied timeslots of a GSM channel

Remote-controlled HF DF station

In conjunction with the wide-aperture DF Antenna R&S®ADD011, the Direction Finder R&S®DDF01E forms a DF system for the HF range of 300 kHz to 30 MHz that is remarkable for its high accuracy and sensitivity.

The large nine-element DF antenna of 50 m in diameter combines with the correlative interferometer to make the direction finder less sensitive to reflections encountered in uneven terrain. This greatly facilitates finding a suitable location for the DF antenna.

The use of crossed loops ensures that bearings will still be taken even of signals incident at steep elevation angles of up to 85°. The elevation angle is also calculated, making the DF antenna ideally suited for single station location.

Superior accuracy and sensitivity

The R&S®DDF01E combined with the R&S®ADD011, therefore, offers a typical DF accuracy of 1° RMS and a typical sensitivity of 0.25 µV/m (see specifications) also in real environments that are suitable for direction finding (i.e. not only in an ideal test terrain).



DF Antenna R&S®ADD011

HF direction finders are installed in remote areas, wherever possible. There are two reasons for this:

- ◆ Man-made noise (electromagnetic noise caused by machines and electrical devices) is significantly lower
- ◆ DF accuracy is higher since there are fewer obstacles such as high-tension poles, buildings, streets or roads in the vicinity of the direction finder that would distort the incoming wave field

In such cases, remote control is often required. With the R&S®DDF0xE direction finders, this is implemented by installing the R&S®DDFE-REM software on a commercial PC that is set up close to the DF equipment. In addition to remote control, the software performs intelligent data reduction as required for the available communications link (ISDN, GSM/GPRS, modem etc).

If the DF equipment is accommodated in the All-Weather Cabinet R&S®KK500, a simple shelter will suffice to protect the equipment against theft and vandalism.

Product	Brief description
R&S®DDF01E	Fast HF monitoring direction finder with high accuracy and sensitivity
R&S®ADD011	Wide-aperture HF DF antenna with high accuracy and sensitivity
R&S®DDF-SSL	Single station locator DF software option for locating HF transmitters by means of only a single direction finder, based on ionosphere data
R&S®DDFE-REM	DF option for remote control of the direction finder via ISDN, etc
R&S®KK500	All-weather cabinet for the DF equipment

Mobile HF/VHF/UHF radiomonitoring

To provide mobile detection and direction finding throughout the entire frequency range, it takes compact DF equipment, broadband DF antennas and appropriate DF methods.

300 kHz to 3 GHz with three compact DF antennas

Rohde & Schwarz offers optimized DF equipment and antennas that provide seamless coverage in the frequency range 300 kHz to 3 GHz. The complete range is covered by only three DF antennas that deliver very good results despite their small dimensions. Above 200 MHz, the mobile system offers DF accuracy and sensitivity as high as that of the stationary system.

300 kHz to 3 GHz with just eight height units

The R&S®DDF05E with the R&S®DDFE-HF option provides coverage of the entire frequency range, taking up only eight height units, which is a remarkably compact size for a direction finder as powerful as that. Above 20 MHz, signal processing is carried out in the same way as with the stationary system, i.e. by means of three preselectors and converters. In the HF range, by contrast, the three channels are switched directly to the A/D converters of the DF processor, and the receive paths are implemented in the form of digital software receivers.

The DF Antenna R&S®ADD119 was developed for mobile HF direction finding. The antenna consists of a crossed loop and a reference antenna, which combine to form a classic Watson-Watt DF antenna. The antenna is designed for ground waves up to 30 MHz and, despite its small dimensions, offers a DF accuracy of 2° RMS as well as high sensitivity.

With the R&S®ADD119, the direction finder switches automatically to the Watson-Watt method when HF is selected. The antenna and the tripod are mounted in next to no time.

The VHF/UHF range up to 1300 MHz is covered by the DF Antenna R&S®ADD153. The antenna can be flat-mounted on a vehicle roof using an adapter and, if required, camouflaged under an elevated plastic roof.

The DF Antenna R&S®ADD070 extends the frequency range up to 3 GHz and is also available as a flat model. The figure in the upper right shows the antenna mounted on a telescopic mast, which significantly increases the DF range.

Error correction on request

Especially in the range below 200 MHz, DF accuracy is generally restricted by resonances and reflections. To minimize impairment of DF quality by such effects, Rohde & Schwarz will on request calibrate your DF vehicle on a turntable. With calibration, DF accuracy is on average twice as high as without calibration.



VHF/UHF DF vehicle



DF Antenna R&S®ADD119

Product	Brief description
R&S®DDF05E	Fast VHF/UHF monitoring direction finder with high accuracy and sensitivity
R&S®DDF E-HF	DF option extending the VHF/UHF Direction Finder R&S®DDF05E to include the HF band
R&S®ADD119	Compact Watson-Watt HF DF antenna
R&S®ADD153	VHF/UHF DF antenna for the frequency range 20 MHz to 1300 MHz
R&S®ADD070	DF antenna for the frequency range 1300 MHz to 3000 MHz (flat model for mounting on a vehicle roof)
R&S®AP502Z1	Adapter for flat-mounting of the R&S®ADD153 on a vehicle roof

Options

Direction finding of GSM mobile phones

R&S® DDF-GSM option

With this option, the R&S® DDF 05E enables quasi-simultaneous direction finding of all mobile phones active in a channel. A bearing is determined for each occupied timeslot. Only in this way is it possible to locate a mobile phone in a densely occupied radio scenario.

**Reliable bearings
in densely occupied radio scenarios**

Mobile phones transmit information in short bursts of 577 μ s. Requiring a minimum signal duration of only 400 μ s, the R&S® DDF 05E is able to capture these extremely short-term emissions. The main task of the GSM option is to cause the direction finder to start the measurement exactly when the mobile phone starts transmitting. This can be done in three ways:

- ◆ The R&S® DDF 05E is synchronized to the base station to which the mobile phone is connected.
- ◆ An external trigger signal informs the R&S® DDF 05E of the start of an emission.
- ◆ The R&S® DDF 05E is supplied with a highly stable clock signal (e.g. GPS) and synchronized to the base station only once. Depending on the stability of the external clock signal, the direction finder remains synchronized to the base station for many hours.

Automatic preclassifier

R&S® DDF-CL option

Personnel involved in military radio-monitoring in particular has to cope with increasingly complex radio scenarios. The spectrum occupancy is steadily increasing, while the techniques

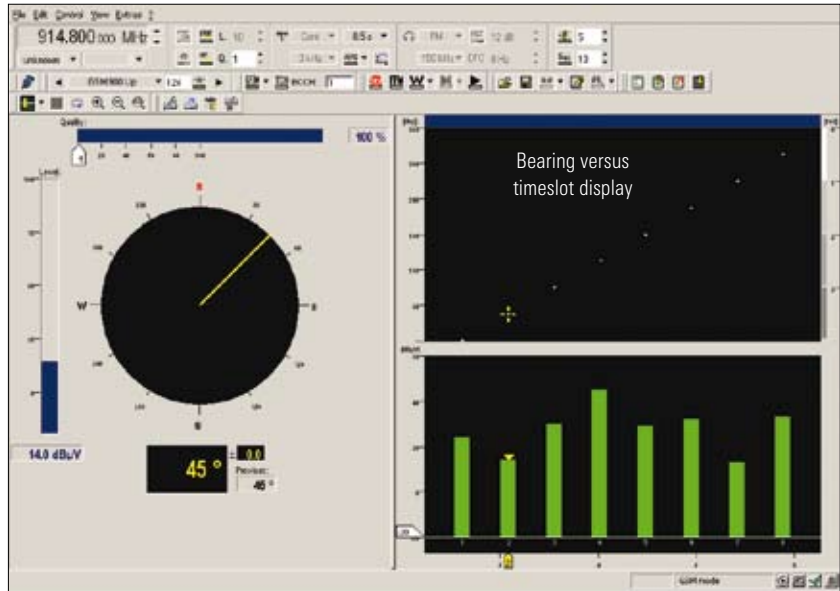

R&S® DDF-GSM option: control software in GSM mode with eight mobile phones

employed to camouflage radio emissions are becoming more and more sophisticated.

Consequently, the probability increases that, for example, frequency hoppers operating in large bandwidths or short bursts emitted at unknown frequencies will go unnoticed.

The preclassifier ensures that virtually every signal will be detected.

**Automatic detection of
hoppers, bursts and chirps**

After a start and a stop frequency is entered, the frequency range is continuously scanned and results are stored. Any new signals detected are compared with the results previously stored. If a specific pattern is recognized (e.g. several burst emissions from the same direction, indicating a frequency hopper), the signal in question is classified as belonging to

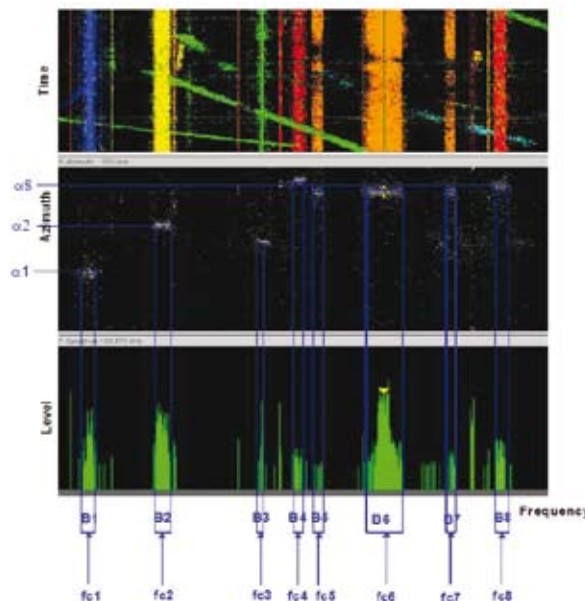

R&S® DDF-CL option: principle of preclassification

one of the following categories: fixed frequency, hopper, chirp or burst. Individual results are averaged to form an overall result. The preclassifier option, therefore, provides the basic functionality needed for the automatic location of LPI signals.

This technique not only offers the advantage of being independent of the operator's expertise, but also another important asset, i.e. data reduction.

Maximum data reduction

Radiolocation networks consisting of several direction finders transfer DF results to a central station. The smaller the amount of data to be transferred, the less conspicuous the data transmission. Preclassification maximally reduces data, leaving only the essential information to be transmitted.

High frequency resolution

R&S®DDF-HFR option

The R&S®DDF0xE offers high frequency resolution as standard (HF: 200 Hz, VHF/UHF: 1000 Hz), which is sufficient for most applications. Some applications, however, require extremely high resolution, for example:

- ◆ Direction finding of co-channel interferers: if two transmitters operate in an overlapping spectrum, the bearing error increases and the bearing may even be invalid.
- ◆ Direction finding of hidden signals: the same applies as in the case of co-channel transmitters. The difference is that the signal searched for deliberately conceals itself in the spectrum of an FM or TV broadcast transmitter, for example.

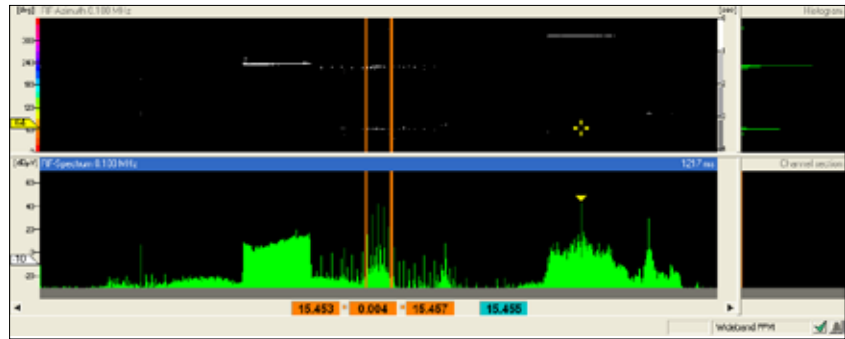

R&S®DDF-HFR option: direction finding of two emitters in the same frequency range with 20 Hz resolution

New: extremely high frequency resolution on request

Due to the extremely high frequency resolution achieved with the R&S®DDF-HFR option, the R&S®DDF0xE calculates up to a hundred times more bearings per frequency band. As a result, statistical functions such as the histogram and the sliding averaging function yield more accurate results in considerably less time. Moreover, a greater number of interference-free bearings is obtained since, at the instant a bearing is taken, only one transmitter emits a signal at that specific frequency.

The figure above shows a measurement in the WFFM mode with a resolution of 20 Hz. In the range marked by the two orange lines, a co-channel interferer is superimposed on the signal of interest. Owing to the high resolution, two maxima are clearly discernible in the histogram, and accurate bearings can be taken.

Remote control

R&S®DDF E-REM option

There are two main reasons for operating the R&S®DDF0xE by remote control: improved receive characteristics and simplified control of DF networks.

Remote control via virtually any data link

Improvement of receive characteristics: Man-made noise is particularly high in the shortwave range. Setting up a DF system at a sufficient distance from densely populated areas is therefore mandatory when bearings are to be taken of weak signals. To avoid strong reflections, it is further recommended that HF direction finders be set up as far away as possible from buildings, high-tension lines, streets and roads. If the DF operators themselves are not stationed at such remote locations, remote control is the solution.

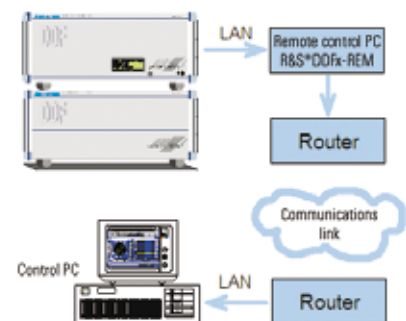

R&S®DDF E-REM option

Simplification of DF network operation: If several direction finders are connected to form a network, central control is a great advantage as experienced users are needed only at a single station.

The R&S®DDFE-REM remote control software is installed on a commercial PC close to the DF equipment. Data transmission is organized by commercial routers. Any desired communications link can be used:

- ◆ ISDN
- ◆ GSM/GPRS
- ◆ Satellite link
- ◆ Radio modems
- ◆ Microwave link
- ◆ ... plus many more

The R&S®DDFE-REM software not only provides remote control, but also performs other tasks:

- ◆ Intelligent data reduction to adjust the data volume to be transmitted to the available communications link
- ◆ Audio data compression
- ◆ Multiple station management

Single station locator

R&S®DDF-SSL option

The shortwave range offers the special opportunity of locating transmitters by means of a single direction finder if their signals are propagated via skywaves. Direction finding makes use of the fact that the shortwave signal is reflected by the ionosphere, and the transmitter location is calculated following the law of angle of incidence being equal to the angle of reflection. The R&S®DDF01E calculates the elevation. The DF quality filter and the histogram function are available for data averaging.

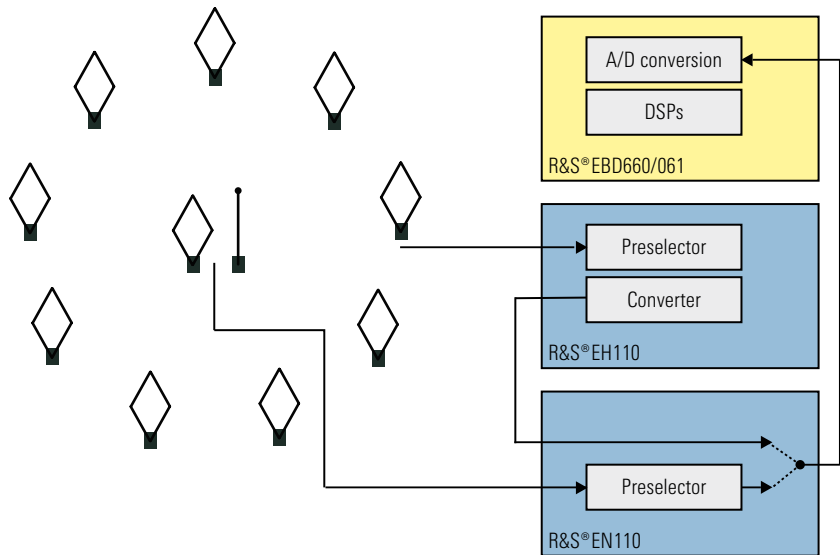

R&S®DDF-LF option

Easy and fast operation due to integrated ionosphere database

The height of the ionosphere can be conveniently calculated after entering the current smoothed number of sunspots into the DF system. This information is available in a database, which contains the averaged data of many years and is very accurate. All parameters can of course also be user-defined.

The R&S®DDF-SSL option also offers the possibility of calibrating the height of the ionosphere using a transmitter with a known position.

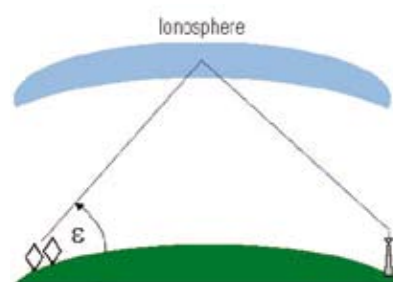

R&S®DDF-SSL option

VLF extension

R&S®DDF-LF option

New: direction finding down to 9 kHz

The R&S®DDF-LF extension expands the R&S®DDF0xE frequency range down to 9 kHz. The frequency range from 1 MHz to 30 MHz may be covered by the DF Antenna R&S®ADD011, for example. Below 1 MHz, a classic Watson-Watt DF antenna consisting of a crossed-loop antenna and a monopole can be used.

Bearings are determined using either the correlative interferometer or the Watson-Watt method, depending on the frequency, thus making maximum use of the two methods: high bearing accuracy and compact antenna dimensions.

Signal processing also differs for the two ranges. Above 1 MHz, three classic analog receivers with a preselector and a converter are employed. Below this frequency, the receive signals are merely passed through a broadband filter and then applied directly to the A/D converters. Subsequent filtering is performed digitally by means of software receivers.

Synchronous scanning

R&S®DDF-TS option

To locate a transmitter by triangulation, bearings are required of several direction finders. This is ensured for signals with normal transmission duration of a few hundred milliseconds and above.

A key requirement for locating LPI signals

With frequency-agile LPI signals such as hoppers and bursts, the duration of a single transmission is very short. Moreover, the frequency is not known, so that large frequency ranges have to be scanned. It may happen that only one direction finder is operating at the correct frequency at the moment of an emission. Locating the transmitter searched for is then impossible.

Using the R&S®DDF-TS option, the scan activities are synchronized, i.e. each direction finder measures exactly at the same frequency at the same time. A reliable bearing of any detected signal is taken by each direction finder, and the signal is located with maximum accuracy.

Synchronization is highly accurate due to the use of GPS. The R&S®DDF-TS option is therefore an important prerequisite for DF networks locating LPI signals.

Tools for maintenance and troubleshooting

R&S®DDF-SK option

The R&S®DDF-SK service kit option considerably cuts the time required for maintenance and troubleshooting of the R&S®DDF0xE.

Troubleshooting – fast and successful

All tools essential for checking the DF system are conveniently accommodated in a rugged case. An important tool is the Antenna Simulation R&S®ZT660, which is connected to the direction finder instead of the DF antenna to perform system tests. It can be set to simulate any desired Rohde & Schwarz DF antenna. Using the antenna simulation, it can conveniently be checked whether a fault originates from the DF antenna or the DF equipment. This relieves the operator from having to climb the antenna mast

or even dismount the DF antenna unnecessarily. The antenna simulation also allows a signal generator to be connected to the DF system, and to take test bearings of its signals with a predefined direction.

The service kit contains the following test equipment:

- ◆ Antenna Simulation R&S®ZT660
- ◆ Various cables and adapters
- ◆ Various tools for opening housings and enclosures

The following tests can be performed, for example:

- ◆ Localization of faults as originating from the DF equipment or DF antenna
- ◆ Testing of the three receive paths
- ◆ Taking a test bearing of signals with known direction

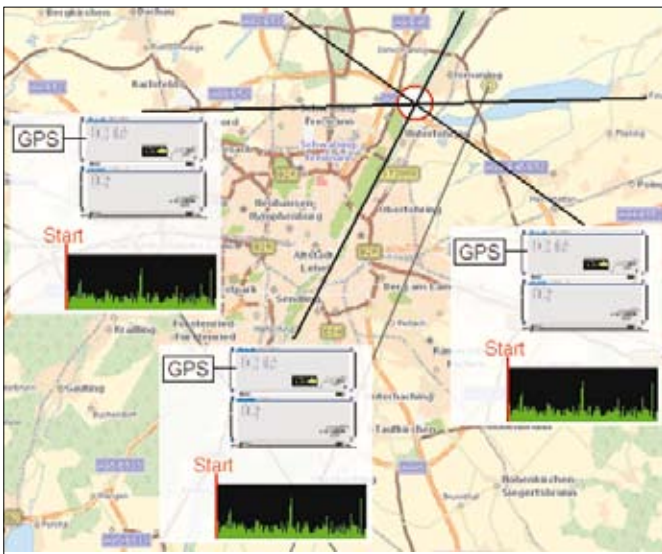

R&S®DDF-TS option

HF extension for the VHF/UHF direction finder

R&S®DDFE-HF option

The R&S®DDFE-HF option turns the VHF/UHF Direction Finder R&S®DDF05E into an extremely compact full-range direction finder covering the frequency range from 300 kHz to 3 GHz. Since the R&S®DDFE-HF is a pure software option, it does not increase the size of the direction finder.

A compact HF DF antenna, for example the R&S®ADD119, is connected to the DF Converter R&S®ET550. When VHF/UHF is selected, the antenna signals are routed through the preselectors and converters. When HF is selected, the antenna signals

are directly applied to the A/D converters of the DF processor. After A/D conversion, preselection and conversion of the HF signals are performed by software receivers. Bearings are calculated employing the correlative interferometer or the Watson-Watt method, depending on the DF antenna used.

The fact that the HF signals are directly applied to the A/D converters without a narrowband preselector like R&S®EM110 slightly increases the direction finder's sensitivity to strong transmitters. However, since the R&S®DDFE-HF option is normally used with compact and therefore less sensitive DF antennas, this disadvantage can be considered insignificant.

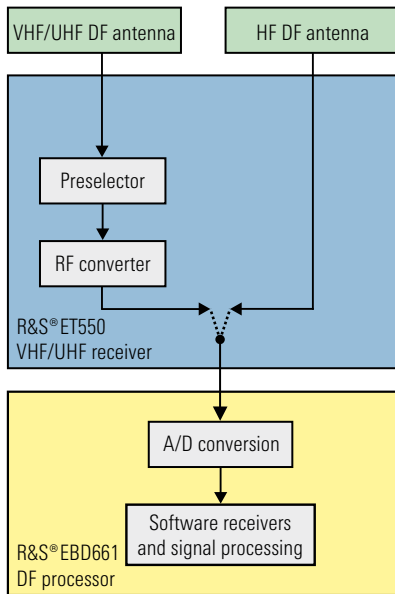

R&S®DDFE-HF option

Output of digitized raw data

R&S®DDF-DR option

If the R&S®DDF0xE is used as a data source for an analysis system such as R&S®AMMOS, digitized, unprocessed intermediate-frequency (IF) data has to be output.

New: raw data output for analysis

The R&S®DDF-DR option allows raw data to be output via a standardized FPDP interface. The digitized IF data of the three receive paths are brought out at this interface and can be recorded by means of the R&S®AMREC, for example.

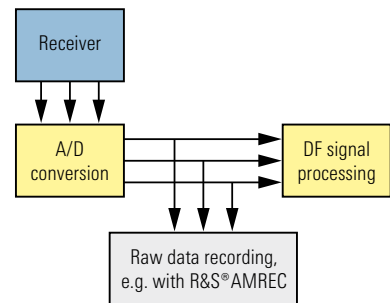

R&S®DDF-DR option

DF antennas

The direction finders of the R&S®DDF0xE family operate with the DF Antennas R&S®ADDx, which are also used for the R&S®DDF0xM, R&S®DDF0xS and R&S®DDF0xA families of direction finders.

In many cases, existing DF antennas (especially HF Adcock antennas) from other manufacturers can be used. In these cases, the Antenna Interface R&S®GX060 is required. The details must be verified from case to case.

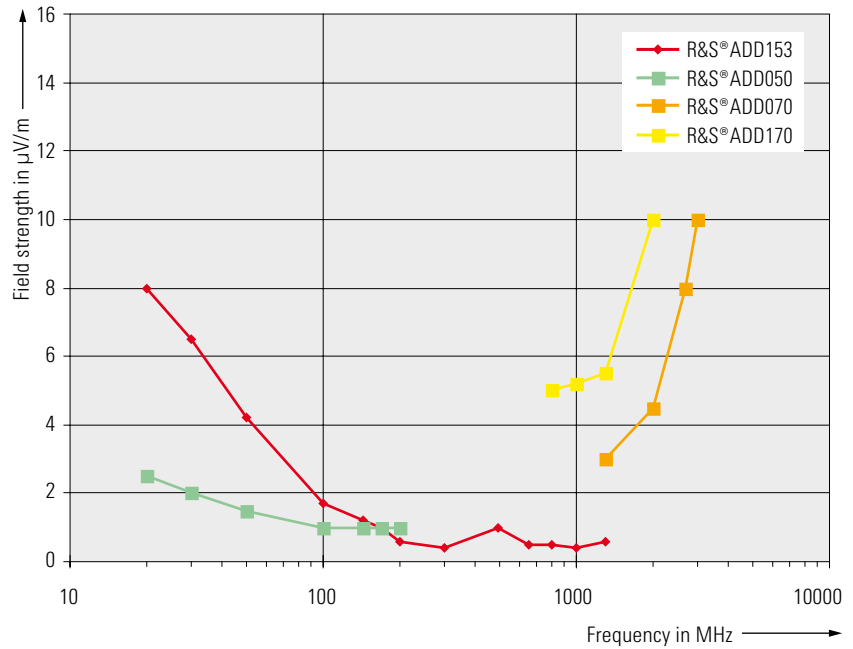
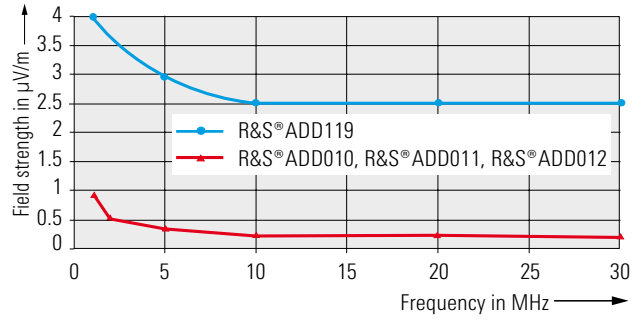

Sensitivity of DF antennas; averaging time 1 s, bearing fluctuation 2° RMS, bandwidth 1 kHz



All DF antennas mentioned here are described in detail in the R&S®ADDx DF antenna data sheet

Specifications – HF antennas

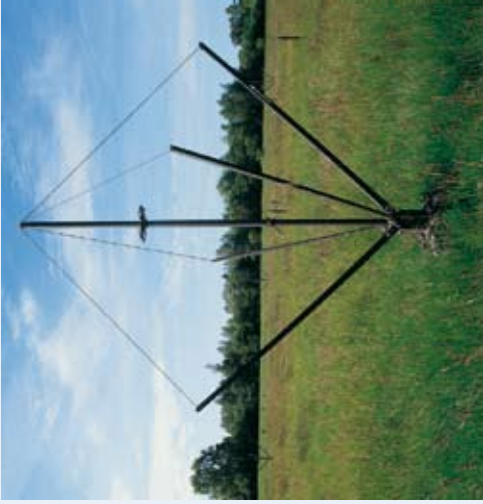
Type (Order No.)	R&S® ADD119 (4053.6509.02)	R&S® ADD010 (4045.0105.03)	R&S® ADD011 (4045.0005.13)
			
	mobile, fast scanning for ground waves and sky waves with low elevation angle	semimobile and stationary, for signals with elevation angle $\leq 50^\circ$, SSL, possible to a limited extent	stationary, for signals with elevation angle $\leq 85^\circ$, SSL, possible
Frequency range	(0.3 MHz) 1 MHz to 30 MHz, below 1 MHz with limited sensitivity and accuracy		
Antenna type	1 crossed loop and 1 active dipole	active 9-element circular array of rod antennas	active 9-element circular array of crossed loop antennas
DF method	Watson-Watt	correlation	correlation
Polarization	vertical	vertical	vertical, horizontal, circular
DF accuracy ¹⁾	2° RMS	1° RMS	1° RMS
Sensitivity	typ. 4 $\mu\text{V/m}$ to 2.5 $\mu\text{V/m}$ (2° bearing fluctuation, 1 kHz bandwidth, 1 s averaging time)	typ. 1 $\mu\text{V/m}$ to 0.2 $\mu\text{V/m}$ (2° bearing fluctuation, 1 kHz bandwidth, 1 s averaging time)	typ. 1 $\mu\text{V/m}$ to 0.2 $\mu\text{V/m}$ (2° bearing fluctuation, 1 kHz bandwidth, 1 s averaging time)
Power supply	from DF equipment	from power supply built in as standard	from power supply built in as standard
Dimensions (approx.)	1100 mm diameter \times 232 mm height	antenna circle: 50 m diameter, height of rod antenna: 2 m	antenna circle: 50 m diameter, height of crossed loop: 3.5 m incl. tripod
Color	RAL 1015	RAL 6014	RAL 6014
Weight (approx.)	25 kg	single element with base plate: 14 kg, network: 22 kg	single element with base plate: 32 kg, network: 22 kg

¹⁾ Measurement in reflection-free environment. The RMS error is calculated from the bearings of an evenly distributed azimuth and frequency sample.

Specifications – VHF/UHF antennas

Type (Order No.)	R&S® ADD153 (4053.0003.02)	R&S® ADD050 (4041.4006.02)	R&S® ADD053 (4062.8800.02)	R&S® ADD070 (4043.4003.02/.12) ²	R&S® ADD070M (4059.6000.02)	R&S® ADD170 (4055.7502.12)
						
Application	VHF/UHF, mobile and stationary	VHF, stationary, enhanced accuracy especially with multipath propagation 20 MHz to 200 MHz	VHF/UHF, stationary, combination of R&S® ADD153 and R&S® ADD050 20 MHz to 1300 MHz	UHF, stationary, can be mounted below VHF/UHF antennas on same mast 1300 MHz to 3000 MHz	UHF, mobile	optimized for mobile direction finding in GSM bands
Frequency range	20 MHz to 1300 MHz	20 MHz to 200 MHz	20 MHz to 1300 MHz	1300 MHz to 3000 MHz	1300 MHz to 3000 MHz	800 MHz to 2000 MHz
Antenna type	9 active antenna elements in radome	active 9-element circular array	2 × active 9-element circular array	8-element circular array	8-element circular array	8-element circular array with center antenna
DF method	correlation	correlation	correlation	correlation	correlation	correlation
Polarization	vertical	vertical	vertical	vertical	vertical	vertical
DF accuracy ¹⁾	2° RMS (20 MHz to 200 MHz) 1° RMS (200 MHz to 1300 MHz)	1° RMS	1° RMS	2° RMS	2° RMS	2° RMS
Sensitivity	typ. 8 µV/m to 0.5 µV/m (2° bearing fluctuation, 1 kHz bandwidth, 1 s averaging time)	typ. 2.5 µV/m to 1 µV/m (2° bearing fluctuation, 1 kHz bandwidth, 1 s averaging time)	typ. 0.5 µV/m to 1 µV/m (2° bearing fluctuation, 1 kHz bandwidth, 1 s averaging time)	typ. 3 µV/m to 10 µV/m (2° bearing fluctuation, 1 kHz bandwidth, 1 s averaging time)	typ. 3 µV/m to 10 µV/m (2° bearing fluctuation, 1 kHz bandwidth, 1 s averaging time)	typ. 5 µV/m to 10 µV/m (2° bearing fluctuation, 1 kHz bandwidth, 1 s averaging time)
Wind load/center of wind load Without ice deposit	at 188 km/h: 710 N/210 mm	at 188 km/h: 1700 N/380 mm	at 188 km/h: 2700 N/800 mm	at 180 km/h: 200 N/250 mm (model .12) at 200 km/h: 530 N/620 mm (model .02)	at 180 km/h: 199 N/170 mm	at 180 km/h: 350 N/180 mm
With 30 mm ice deposit	at 162 km/h: 770 N/270 mm	at 162 km/h: 2800 N/410 mm	at 162 km/h: 3700 N/690 mm	at 140 km/h: 210 N/260 mm (model .12) at 176 km/h: 530 N/680 mm (model .02)	at 140 km/h: 160 N/180 mm	at 140 km/h: 280 N/200 mm
Power supply	from DF equipment	from DF equipment, Power Supply R&S® IN061 may be required for cables with a length >20 m (details upon request)	from DF equipment	from DF equipment	from DF equipment	from DF equipment
Dimensions (approx.)	1100 mm diameter × 297 mm height (height incl. lightning rod: 1327 mm)	antenna circle: 3 m diameter, height: 800 mm, with lightning rod: 3 m	antenna circle: 3 m diameter, height: 800 mm, with lightning rod: 3 m	340 mm diameter × 1200 mm height (model .02) 340 mm diameter × 492 mm height (model .12)	455 mm diameter × 364 mm height	455 mm diameter × 393 mm height
Color	RAL 1015	RAL 1015	RAL 1015	RAL 1015	RAL 1015	RAL 1015
Weight (approx.)	30 kg	70 kg	114 kg	90 kg (model .02), 11 kg (model .12)	11 kg	11 kg

¹⁾ Measurement in reflection-free environment. The RMS error is calculated from the bearings of an evenly distributed azimuth and frequency sample.

²⁾ Model .12: lightweight model for mobile use.

Specifications – R&S®DDF 01E

Frequency range	0.3 MHz to 30 MHz
DF method	correlative interferometer, Watson-Watt
Operation	via graphical user interface (GUI) on external PC with Windows XP
Instrument DF accuracy	0.5° RMS
System DF accuracy (in test field) with R&S®ADD010 or R&S®ADD011	1° RMS
Display	azimuth versus frequency, level versus frequency, polar diagram, histogram, waterfall, realtime IF panoramic display (bandwidth 20 kHz or 1 MHz)
Display resolution	0.1° or 1° (selectable)
DF sensitivity	typ. 0.2 µV/m to 0.5 µV/m (see diagram for HF DF antennas, page 18)
Operating modes	SCAN (f-SCAN, m-SCAN), SEARCH, fixed frequency mode (FFM), wideband mode (WFFM)
Instantaneous bandwidth	1 MHz
Frequency span in wideband mode	1 MHz with R&S®DDF-HFR option additionally: 0.5 MHz/0.2 MHz/0.1 MHz
Minimum signal duration ¹⁾ (depending on selected FFT realtime bandwidth)	
Correlative interferometer	1 ms
Watson-Watt	0.3 ms
Scan speed with 20 kHz resolution, 100% channel occupancy, BT = 4	
Correlative interferometer	up to 450 MHz/s (incl. calculation of elevation)
Watson-Watt	up to 1700 MHz/s
Scan speed with 5 kHz resolution, 100% channel occupancy, BT = 4	
Correlative interferometer	up to 120 MHz/s (incl. calculation of elevation)
Watson-Watt	up to 500 MHz/s
Processing speed	
Correlative interferometer	up to 25 000 channels/s (incl. calculation of elevation)
Watson-Watt	up to 100 000 channels/s
Channel spacing (depending on selected FFT realtime bandwidth)	20 kHz/10 kHz/5 kHz/2 kHz/1 kHz/0.5 kHz/0.2 kHz with R&S®DDF-HFR option additionally: 0.1 kHz/0.05 kHz/0.02 kHz

Bandwidths	
Direction finding	12 kHz/6 kHz/3 kHz/1.2 kHz/0.6 kHz/0.3 kHz/0.12 kHz
Demodulation	20 kHz/12 kHz/10 kHz/6 kHz/3.4 kHz/3 kHz/1.2 kHz/0.6 kHz/0.3 kHz/0.12 kHz/0.06 kHz
Adjacent channel suppression ≥10 kHz	80 dB (FFM), 60 dB (SCAN)
Modes of demodulation	CW, AM, FM, SSB
Filter selectivity (shape factor, 60 dB/3 dB)	2.5 (FFM) 3.6 (SCAN)
Dynamic range (incl. AGC)	>120 dB
Linearity	
Second-order intercept (SOI)	≥75 dBm, typ. 85 dBm
Third-order intercept (TOI) ²⁾	≥32 dBm, typ. 39 dBm
Intermodulation-free dynamic range	typ. 95 dB (in-band, bandwidth of 1.2 kHz)
Phase noise	<-110 dBc (1 Hz) at 1 kHz offset typ. -116 dBc (1 Hz) at 1 kHz offset
Impedance	50 Ω
Frequency stability	1 × 10 ⁻⁷ at -10 °C to +55 °C
Frequency setting accuracy	1 Hz
Image frequency rejection	>95 dB, typ. 110 dB
IF rejection	>95 dB, typ. 110 dB
MTBF	
R&S®EBD061	>28 000 h
R&S®EH110	>60 000 h

- 1) 100% probability of intercept for a single burst emission within realtime bandwidth. Lower values are possible for measurements performed with multiple burst emissions and reduced probability of intercept.
- 2) Frequency separation between intermodulating signals ≥30 kHz. Higher values are possible for measurements performed at larger frequency separation.

Specifications – R&S®DDF 05E

Frequency range	20 MHz to 3000 MHz 300 kHz to 3000 MHz with R&S®DDFE-HF option
DF method	correlative interferometer, Watson-Watt
Operation	via graphical user interface (GUI) on external PC with Windows XP
Instrument DF accuracy	0.5° RMS
System DF accuracy (in test field) With R&S®ADD053 With R&S®ADD070	1° RMS 2° RMS
Display	azimuth versus frequency, level versus frequency, polar diagram, histogram, waterfall, realtime IF panoramic display (bandwidth 100 kHz or 2 MHz)
Display resolution	0.1° or 1° (selectable)
DF sensitivity 20 MHz to 1300 MHz 1300 MHz to 3000 MHz	typ. 0.5 µV/m to 1 µV/m typ. 3 µV/m to 10 µV/m (see diagram for VHF/UHF DF antennas, page 18)
Operating modes	SCAN (f-SCAN, m-SCAN), SEARCH, fixed frequency mode (FFM), wideband mode (WFFM)
Instantaneous bandwidth	2 MHz with R&S®DDFE-HBW option: 10 MHz (–6 dB)
Frequency span in wideband mode	2 MHz with R&S®DDFE-HBW option: 10 MHz with R&S®DDF-HFR option additionally: 1 MHz/0.5 MHz/0.2 MHz/0.1 MHz
Minimum signal duration ¹⁾ (depending on selected FFT realtime bandwidth) Correlative interferometer Watson-Watt	400 µs 150 µs
Scan speed with 100 kHz resolution, 100% channel occupancy, BT = 4 Correlative interferometer Watson-Watt	5.7 GHz/s with R&S®DDFE-HBW option: 10 GHz/s 20 GHz/s
Scan speed with 25 kHz resolution, 100% channel occupancy, BT = 4 Correlative interferometer Watson-Watt	2 GHz/s 8.5 GHz/s
Processing speed Correlative interferometer Watson-Watt	up to 80 000 channels/s with R&S®DDFE-HBW option: up to 100 000 channels/s up to 300 000 channels/s
Channel spacing (depending on selected FFT realtime bandwidth)	100 kHz/50 kHz/25 kHz/20 kHz/ 12.5 kHz/10 kHz/8.33 kHz/5 kHz/ 2 kHz/1 kHz with R&S®DDF-HFR option additionally: 1 kHz/0.5 kHz/0.2 kHz/ 0.1 kHz/0.05 kHz/0.02 kHz

Bandwidths Direction finding	60 kHz/30 kHz/15 kHz/12 kHz/ 7.5 kHz/6 kHz/5 kHz/3 kHz/1.2 kHz/ 0.6 kHz
Demodulation	150 kHz/60 kHz/30 kHz/15 kHz/ 12 kHz/7.5 kHz/5 kHz/3 kHz/ 1.2 kHz/0.6 kHz
Adjacent channel suppression ≥10 kHz	80 dB (FFM), 60 dB (SCAN)
Modes of demodulation	CW, AM, FM, SSB
Filter selectivity (shape factor 60 dB/3 dB)	2.5 (FFM) 3.6 (SCAN)
Dynamic range (incl. AGC)	>120 dB
Linearity Second-order intercept (SOI) Third-order intercept (TOI) ²⁾	≥50 dBm, typ. 63 dBm ≥18 dBm, typ. 28 dBm
Intermodulation-free dynamic range	typ. 85 dB (in-band, bandwidth of 7.5 kHz)
Phase noise	<–116 dBc (1 Hz) at 10 kHz offset typ. –120 dBc (1 Hz) at 10 kHz offset
Impedance	50 Ω
Frequency stability	1 × 10 ^{–7} at –10 °C to +55 °C
Frequency setting accuracy	1 Hz
Image frequency rejection	>90 dB, typ. 110 dB
IF rejection	>95 dB, typ. 110 dB
MTBF R&S®EBD061 R&S®ET550	>28 000 h >25 000 h

- 1) 100% probability of intercept for a single burst emission within realtime bandwidth. Lower values are possible for measurements performed with multiple burst emissions and reduced probability of intercept.
- 2) Frequency separation between intermodulating signals ≥2.2 MHz. Higher values are possible for measurements performed at larger frequency separation.

General data

(valid for R&S®DDF01E, R&S®DDF05E and R&S®DDF06E)

	R&S®EBD061	R&S®EH110	R&S®ET550
Operating temperature range	-10 °C to +55 °C, meets EN 60068-2-1, EN 60068-2-2, MIL-STD-810E Meth. 501.3/502.3		
Storage temperature range	-40 °C to +71 °C, meets EN 60068-2-1, EN 60068-2-2, MIL-STD-810E Meth. 501.3/502.3		
Humidity/damp heat	max. 80 % cycl. test at 25 °C/40 °C, meets EN 60068-2-30 max. 95 % rel. humidity, without condensation, meets MIL-STD-810E Meth. 507.3, without cyclic condensation		
Mechanical resistance/shock	30 g, 11 ms semi-sinewave, meets EN 60068-2-27 40 g shock spectrum, 45 Hz to 200 Hz, meets MIL-STD-810E, Meth. 516.4		
Vibration			
Sinusoidal	5 Hz to 55 Hz, max. 2 g, 55 Hz to 150 Hz, 0.5 g const., 12 min/(3)axis, meets EN 60068-2-6		
Random	10 Hz to 500 Hz, 1.9 g (RMS), 30 min/(3)axis, meets EN 60068-2-64		
EMC	30 MHz to 1000 MHz, 30/37 dBµV/m, field strength (emission), meets EN 55022 0.15 MHz to 30 MHz, class B interference voltage on AC power lines, meets EN 55022 0 Hz to 2 kHz interference current on AC power lines, meets EN 61000-3-2 ±8 kV/±4 kV static discharge, meets EN 61000-4-2 80 MHz to 1000 MHz, 10 V/m field strength (immunity), meets EN 61000-4-3 ±2 kV/±1 kV transient burst at AC power/signal connection (immunity), meets EN 61000-4-4 ±2 kV/±1 kV burst (immunity), meets EN 61000-4-5 0.15 MHz to 80 MHz, 10 V unmod./mod. 80 % AM (1 kHz) on lines, meets EN 61000-4-6 10 ms/30 %, 100 ms/60 % voltage reduction, 5 s voltage interruption on AC power lines, meets EN 61000-4-11		
Power supply	100 V to 230 V AC, +10 %/-12 %, 47 Hz to 63 Hz		
Electrical safety (meets EN 61010, VDE 0411)	max. 350 VA, typ. 250 VA	max. 150 VA, typ. 120 VA	max. 200 VA, typ. 180 VA
Dimensions (W × H × D)	436 mm × 192 mm × 460 mm (19" × 4 HU)		
Weight	approx. 15 kg	approx. 16 kg	approx. 18 kg

Ordering information

Order designation	Type	Order No.
Digital HF Monitoring Direction Finder	R&S®DDF01E	4059.9600.02
Digital VHF/UHF Monitoring Direction Finder	R&S®DDF05E	4059.9700.02
Digital HF/VHF/UHF Monitoring Direction Finder	R&S®DDF06E	4059.9800.02
Antennas (see separate data sheet)	R&S®ADDx	see tables on pages 19 and 20
Options		
Master Slave Handover	R&S®RA-MSH	3020.9690.02
LF Extension	R&S®DDF-LF	4060.0348.02
GSM Interception	R&S®DDF-GSM	4059.9951.02
Synchronous Scanning	R&S®DDF-TS	4060.0290.02
Raw-Data Recording	R&S®DDF-DR	4060.0390.02
Preclassifier	R&S®DDF-CL	4059.9900.02
Single Station Locator for HF	R&S®DDF-SSL	3020.8864.02
Remote Control Extension	R&S®DDF-E-REM	3020.8841.02
Geographic Information Software	R&S®MapView	4046.1105.02
HF Extension for R&S®DDF05E	R&S®DDF-E-HF	on request
High-Frequency Resolution	R&S®DDF-HFR	on request
Service Kit (for maintenance and troubleshooting)	R&S®DDF-SK	4060.0454.02
High Bandwidth	R&S®DDF-E-HBW	4066.8992.02

The direction finders of the R&S®DDF0xE family can also be integrated in R&S®ARGUS and R&S®RAMON systems (R&S®RAMON

with R&S®MonLoc and R&S®ScanLoc radiolocation software). More information available upon request.



More information at
www.rohde-schwarz.com
(search term: DDF0xE)



ROHDE & SCHWARZ

www.rohde-schwarz.com

Europe: +49 1805 12 4242, customersupport@rohde-schwarz.com
USA and Canada: 1-888-837-8772, customer.support@rsa.rohde-schwarz.com
Asia: +65 65130488, customersupport.asia@rohde-schwarz.com